

See discussions, stats, and author profiles for this publication at: <https://www.researchgate.net/publication/259975220>

# Nural network based Routing Algorithm for cognitive packet network Architecture

Article · February 2014

CITATIONS

0

READS

37

1 author:



[Pradeep Kumara Wijesekara Abeygunawardhana](#)

Sri Lanka Institute of Information Technology

62 PUBLICATIONS 220 CITATIONS

[SEE PROFILE](#)

Some of the authors of this publication are also working on these related projects:



Cloud Robotics [View project](#)



Non invasive blood sugar sensor [View project](#)

## Research Article

## Neural Network Based Routing Algorithm for Cognitive Packet Network Architecture

Pradeep K.W. Abeygunawardhana<sup>Å\*</sup><sup>Å</sup>Member, IEEE, Dilruwan Madubhashitha

Accepted 12 January 2014, Available online 01 February 2014, Vol.4, No.1 (February 2014)

### Abstract

This journal focuses on introducing an adaptive routing algorithm to be used on Wide Area Network(WAN) like Internet, based on the Cognitive Packet Network (CPN) architecture to enhance the Quality of Service (QoS) delivered to the end users. This research focuses on Building on top of the CPN network architecture and introducing a neural network based routing algorithm which would improve the QoS, provide reliable and efficient service which can fulfill the ever growing Internet usage demand. The neural network's task would be learning the network and adapt to any situation through the knowledge gathered. The packets will collectively learn about the network thus the load on the routers will be minimized. This mechanism completely replaces traditional method of routing tables which results in efficient and reliable packet delivery in comparison to current routing protocols like Open Shortest Path First (OSPF). This research has introduced a routing algorithm which is Intelligent, dynamically adapting and self-learning for CPN infrastructure instead of current packet switched network.

**Keywords:** Random Neural Network, Artificial Intelligence, Routing

### 1. Introduction

Internet usage is expanding rapidly in terms of usage as well as applications, and it is widely accepted that the IP based packet switched network is less capable of catering the needs this exponential growth (Matthew Gray *et al*, 1996) Though measures like introducing Internet Protocol Version 6 addressing, enabling localized contents has been taken those have only delayed the inevitable of moving on to a new architecture altogether. Because of this situation in the communication industry there is a strong demand for a new routing architectures/algorithms that can provide more efficient and resilient service to the Internet commodities.

#### A. Connection Types

Most communication networks to-date has been designed to either provide connection-oriented service or connection-less service (Mark Abrams *et al*, 2000). A typical connection-oriented service operates by establishing a permanent connection between the source and the destination nodes across the network and then only data transfer process between the source node and destination node starts. In contrarily in the connectionless services, data is transmitted between a source node and destination node via packets using datagram. This datagram includes the address of the destination node and travels along multiple paths across the network to the

destination node, the paths chosen generally depend upon the conditions in the network accordingly, the packet from the source node can reach the destination node via multiple randomly selected paths. Efficient Message delivery is one of the basic requirements in a typical distributed system like Internet. Most of the recent researchers on this domain have been focused on developing algorithms to provide better QoS (E. Gelenbe *et al*, 2001).

#### B. Quality of Service (QoS)

QoS refers to the capability of a network to provide better service to selected network traffic over wide area networks like frame relay, asynchronous transfer mode(ATM), SONET and IP-routed networks (i.e. Internet) that may use any or all of these underlying technologies.

QoS is identified in 3 major categories (Petr Grygarek *et al*, 2005).

##### 1. Best effort service

This is based on the concept that all the measures will be taken to deliver the data to the destination with no guarantees, it is best explained as a First in First Out queue, which have no differentiation between incoming traffic flows.

##### 2. Differentiated service /Soft QoS

\*Corresponding author: Pradeep K.W. Abeygunawardhana

Traffic is classified and treated based on the merits better/worse than the rest which enables faster handling, better utilization of available bandwidth and enabling to keep the loss rate minimal. This is a statistical preference not a strict rule based system.

### 3. Guaranteed service / Hard QoS

In this QoS category the bandwidth/resource is permanently reserved for specific traffic class or category.

QoS greatly determines the user experience in networks like Internet which is used by different applications ranging from corporate Business to Social networking, but in the current IP based networks QoS is not well satisfied. This research is focused on addressing this issue via self-awareness and autonomous control in networks and distributed systems. Still numbers of groups are working on research projects to find out better solutions for algorithms to offer better QoS.

#### C. Related Work

Many researches which took place in the recent past has resulted in the new network architecture known as Cognitive packet networks (CPN) which is based on collaborative learning (Petr Grygarek *et al*, 2005), (E. Gelenbe, *et al*, 2002 ), and better QoS concepts(D.K.D Madubashita *et al*, 2011), (Leslie Smith *et al*, 2003), (E. Gelenbe *et al*, 2006).

In a typical CPN architecture the network will dynamically search for paths/routes, constantly update and maintain them, as a function of user specified QoS and conditions in the network in a considered point of time. In CPN, each travel of the smart packet in the network autonomously searches out a network path which provides it with the best QoS according to the objectives that are demanded by the connection (End user) itself. In CPN, packets take on the main role and router doesn't have to do much of the processing related to routing. CPN packets are routed using a combination of Reinforced Learning (RL) algorithm and Neural Network (NN) algorithm (Genevieve Orr *et al*, 1999) based on a QoS goal and some other parameters related to Internet routing (i.e. bandwidth, delay etc.).

Artificial neural networks are mathematical or computational models that are closely related to the way of a typical biological neural network perform computations or make decisions. A typical neural network consists of interconnected small processing units known as nodes or neurons in one or many layers that work together towards producing an output function. . Each of these small processing units (Neurons) has a number of internal parameters called weights. The resulting output of a neural network depends on the cooperation of the individual neurons as well as the weighted parameters given to the neural network for decision taking. Processing of information by neural networks is performed parallel instead of sequentially. A change in the weights related to a particular unit will have an effect in the behavior of the whole network and would impact the output. Main focus of this research is to apply neural network

concepts together with reinforced learning concepts to the CPN infrastructure and produces a better and efficient routing algorithm which meets end users QoS requirements. Routing decisions will not be taken by using routing tables just like most of current algorithms tend to do, (This will be an advantage, when it comes to large networks routers have to maintain thousands of records under the routing table. And they have to go through all of them when each time they try to find a possible route) routing decisions will be take using QoS based weights that recoded previously as successful routing paths. These paths will be saved in a location called as a mail-box which resides inside every node (router). This mailbox oriented feature of the AI Based algorithm might not be faster than regular algorithms initially, but it will ultimately become faster and reliable as it learns new routes, adapt to changes in the network and keep records of them.

## 2. Methodology

This experiment was carried out in two phases, 1<sup>st</sup> phase was the initial development of the algorithm and benchmarking it against an already proven routing algorithm (Open Shortest Path First (OSPF) implementation).The 2<sup>nd</sup> phase was improving the intelligent algorithm based on the results and observations of the initial experiment.

### A. Simulation Engine

#### 1. Phase One

Simulation engine (K. Pawlikowski *et al*, 2002), (S. M. Sanchez *et al*, 2007) is a virtual environment, in the first phase the simulator was based on threads on a single computer and both Intelligent algorithm as well as OSPF algorithm was tested in this virtual environment,

#### 2. Phase Two

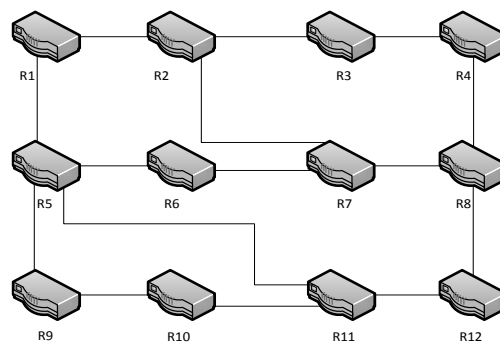
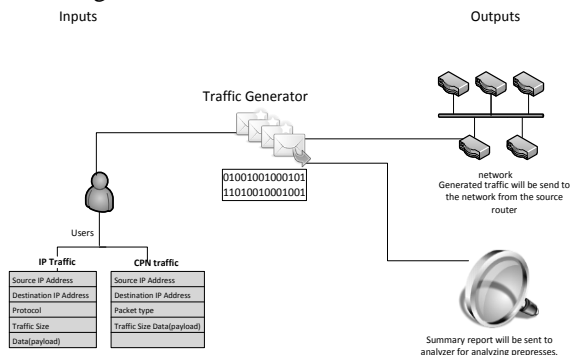

**Fig.1** A sample network layout in the simulator

Second phase was simulated in a virtual machine which acts as a router and eight similar virtual hosts's which acts as inter-connected routers simulating a real network. Each host has a unique IP address and a traffic generator which provides a predefined network traffic amount. This setup was tested for different QoS Goals to measure the performance under various traffic scenarios.

**B. Packet Generator**

This component generates traffic for the Simulation environment. And it is capable of generating volume based traffic with random origins as well as with the option of generating network traffic based on several distributions models (greedy source, Poisson traffic model, and Long-tail traffic models) depending on the user request to ensure that the generated traffic is similar to real network traffic.



**Fig. 2** Packet generator

**C. Traffic Analyzer and Logger**

Statistical information about the transmission of data was captured and logged by this component. The logs are being saved in a centralized database for later use.

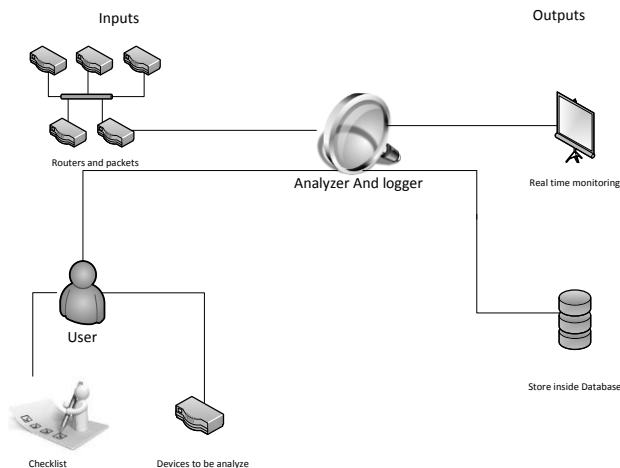

**Fig. 3** Traffic analyzer and logger

**D. Graph/ Chart Generator**

This component is used to graphically elaborate the gathered data organized by scenario based manner.

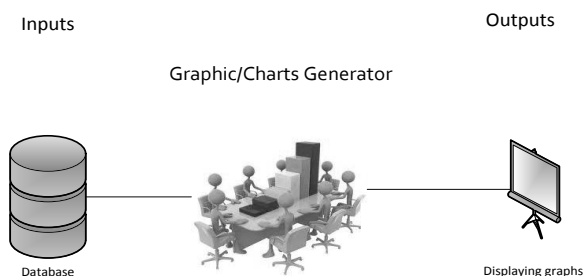

**Fig. 4** Graph/ Chart Generator

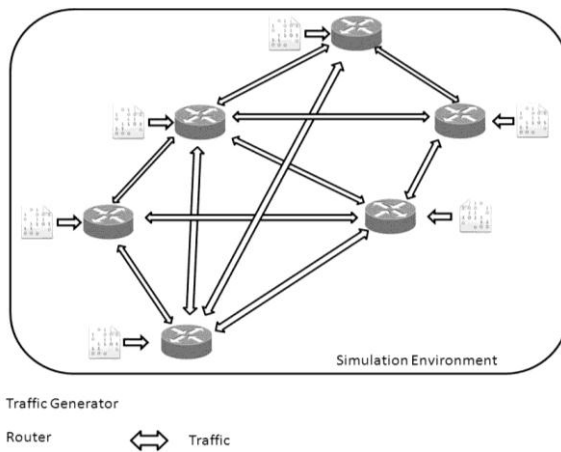

**Fig. 5** Test bed and its major components

**3. Development and Optimization of Neural Network based CPN Routing Algorithm**

An artificial neural network based router system was implemented to carry out the route discovering process of the algorithm depending on the specified QoS goals. In contrast to traditional single best path which will be used in general network traffic regardless of the QoS, our algorithm uses a specific path for each and every the packet which is based on the desired QoS goal. This enables network traffic to differentiate its goals and achieve them. In order to find the paths and take decisions the multi-layer neural network is fed with parameters related to network traffic (bandwidth of the link, delay, required QoS etc.) and the resulting output of the neural network will be the link that should be taken by the intended packet or stream of packets. The executable code (The Logic) is embedded in the packet it-self and the routers provide only the processing power and storage facilities to evaluate the logic and store the ensuing results. This approach makes the system independent of the algorithm and makes it available for future expansion of the algorithm.

CPN infrastructure uses basic 3 kinds of packet types, namely smart packet, dumb packet and acknowledgement packet. Smart packet is responsible for discovering routes; dumb packets deliver the payload to its destinations while Acknowledgement packets are responsible for reliable communication via acknowledgements.

When it is required to send data to a destination node, and if it is the first time that the data is been sent to that particular node, a combination of smart packets and acknowledgement packets will be used to discover the route from source to the destination. Any specified Network related information will be collected by the smart packets and the gathered information will be used to update the special data structures called mailboxes.

After the smart packet reaches its destination, the path followed by the smart packet will be analyzed and the reverse route will be calculated by eliminating the loops and the redundant nodes revisited. Then an acknowledgement packet will be generated by the destination node and send it to the source through the above calculated reverse route.

The mailbox in each node will be updated with every reception of a new acknowledgement appropriately. The entries related to each QoS classes, stored in the mailboxes (When a dumb packet with a new QoS class arrives at the node a new entry for the mailbox will be created) will be used to take decisions when a dumb packet which carries a payload arrives at the node and the entry at the top of the stack belongs to the same QoS class will be used as the switching of the packet is done.

Even in the most recent versions of wide area network routing algorithms, certain fuzzy areas are left behind and not taken into consideration when implementing the strategies of finding the shortest/best paths possible. But in this algorithm through constant updates it is finding more consistent best paths depending on the QoS goals the fuzzy areas including the reliability of the links, packet loss rate, average utilization of a link, security associated with the link will be taken into account.

Each link in a node is represented by a neuron of the Neural Network so the number of neurons at a particular node can vary with the number of network interfaces available and a specific link will be selected as a part of the path if the corresponding neuron to that link is excited. It is said that the neuron is excited if  $x_j(t) > 0$ , where  $x_j(t)$  is the internal potential of neuron  $i$ .

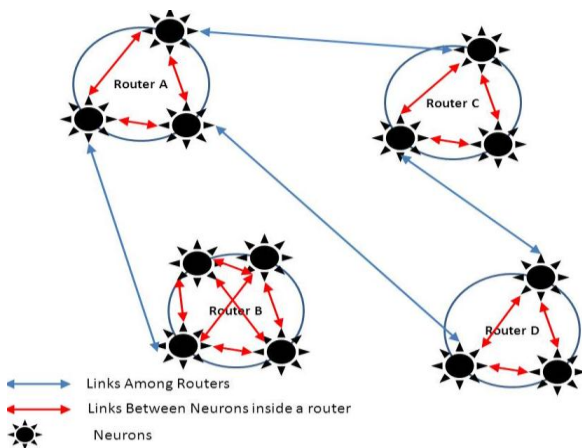

**Fig 6** Representation of the Routers/Nodes with respect to neural Network

$$x_j = \begin{cases} 1 & \text{if } h_j \geq 0 \\ 0 & \text{if } h_j < 0 \end{cases} \quad (1)$$

The internal potential of the neuron  $x_j$  will be 1 only if the sum of the input to the neuron is a positive value.

The probability that the neuron  $i$  of the network is excited is given by  $q_j$ .

$$\lambda^-(i) = \sum_j q_j w_{ji}^- + \lambda_i \quad (2)$$

where the rate of sending excitatory spikes from neuron  $j$  to  $i$  is defined as  $w_{ji}^+$  and the rate of sending inhibitory spikes from neuron  $j$  to  $i$  is defined as  $w_{ji}^-$ . and the total firing rate of neuron  $i$  is given by  $r(i)$ .

$$\lambda^+(i) = \sum_j q_j w_{ji}^+ + \lambda_i \quad (4)$$

$$\lambda^-(i) = \sum_j q_j w_{ji}^- + \lambda_i \quad (5)$$

The optimizations were mainly focused on improving how data is presented to the neural network which can improve the decision making process thus resulting in an efficient network. The main step in that was introducing an index which was then presented to the neural network.

$$\begin{aligned} \text{Weighted Index} = & (\text{QoS Parameter 1 Value} \\ & * \text{Parameter 1's weight} \\ & + \text{QoS Parameter 2's Value} \\ & * \text{Parameter 2's weight} + \dots \\ & + \text{QoS Parameter N's Value} \\ & * \text{Parameter N's weight})/100 \end{aligned}$$

Index is calculated by giving each QoS Parameter a weightage and then multiplying each of the QoS parameter by that weightage. The total of this equals to 100 and the presented value is always between 0 and 1. An example is illustrated below.

$$\begin{aligned} \text{Weighted Index} = & ((\text{Parameter 1' value} * 25 \\ & + \text{Parameter 2's value} * 14 \\ & + \text{Parameter 3's value} * 61))/100 \end{aligned}$$

By introducing this the decision time and the complexity of considering multiple parameters is reduced. This modification also adds the flexibility of having any number of desired QoS parameters without changing either the neural network or the algorithm.

#### 4. Test Results

##### A. Comparison with Existing Algorithm OSPF Test Results

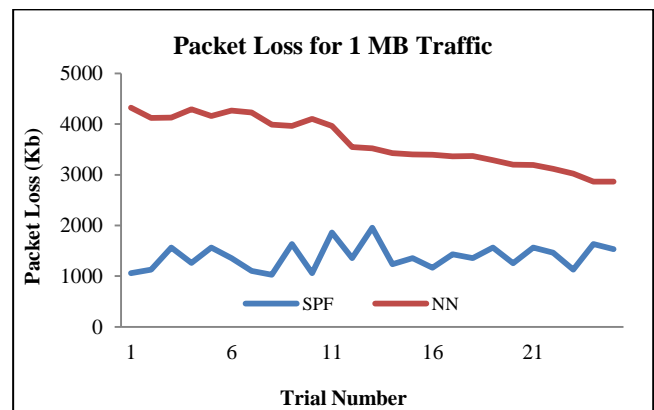
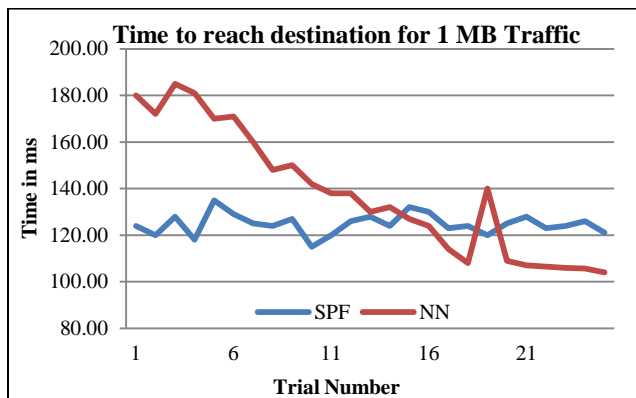

**Fig. 7** Packet Loss at the destination when 1 MB of traffic is sent

Tests were carried out to investigate the time to reach destination for the two network infrastructures during phase One. Each experiment has 8 routers virtually implemented and the topology of the network is kept same for each trial. Time to reach destination from the same origin is measured in mile-seconds. Also there is ever present unwanted network traffic to mimic a typical

network scenario. Both useful traffic and unwanted traffic are generated for each network architecture by the respective traffic generators. The packet loss at the destination is also measured to assess the reliability of the infrastructure.

The test is carried out in network traffic loads as 1MB, 2 MB and 4 MB (Mega Bytes). For all the CPN traffic the QoS goal is set to minimum delay. Time to reach the destination is measured in mille-seconds.



**Fig 8** Time to reach the destination when 1 MB of traffic is sent

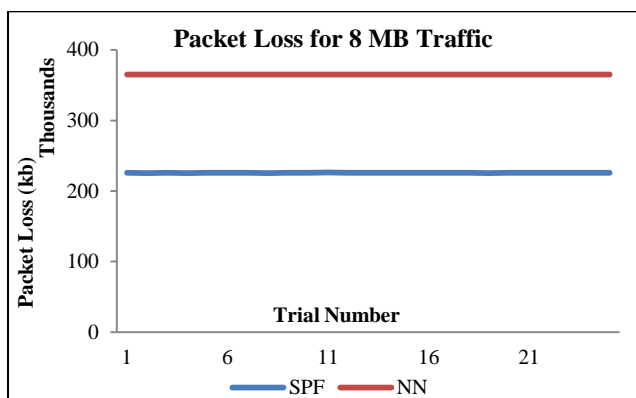

**Fig 9** 8 Packet losses at the destination when 8 MB of traffic is sent

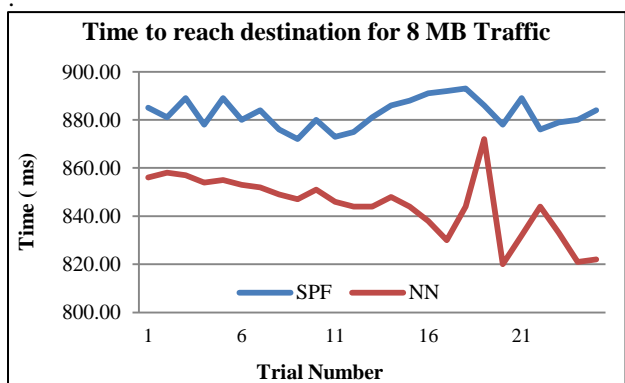

**Fig 10** Time to reach the when 8 MB of traffic is sent

According to these results there is no significant difference to distinguish between the two routing algorithms at the

beginning. But when the Trial number is increased it can be observed that, more the neural network based routing algorithm works the better the results become for all the scenarios. Also it can be seen that In neural network based routing algorithm, number of lost packets and the time taken to reach a particular destination is decreased dramatically while in the Shortest Path First (SPF) algorithm above the same values has maintained a certain consistency. So at the very beginning the neural network based routing algorithm may yield poor results but as the time goes on it is guaranteed that the results will improve and be more precise as well as quick in adopting to changes in the network. This is mainly due to the dynamic learning capability of the routing algorithm where as for the SPF routing algorithm it has to rely on the information provided by the neighboring. So based on these preliminary test results we can make a primary assumption that the neural network based routing algorithm can be a long lasting solution to improve the network’s reliability and performance overtime.

**B. Optimization Test Results**

In the Phase 2, the tests were carried out to investigate the time to reach destination for the CPN network infrastructure under a given QoS goal after optimizations which were earlier described in section E. Each trial has 8 routers virtually implemented and the topology of the network can be altered but it is kept same for each trial.

**Table 1** QoS Variations in the test cases.

Scenario	Minimum Packet loss	Minimum Delay QoS
1	0%	100%
2	25%	75%
3	50%	50%
4	75%	25%
5	100%	0%
6**	This is the data from the Phase One (Before	

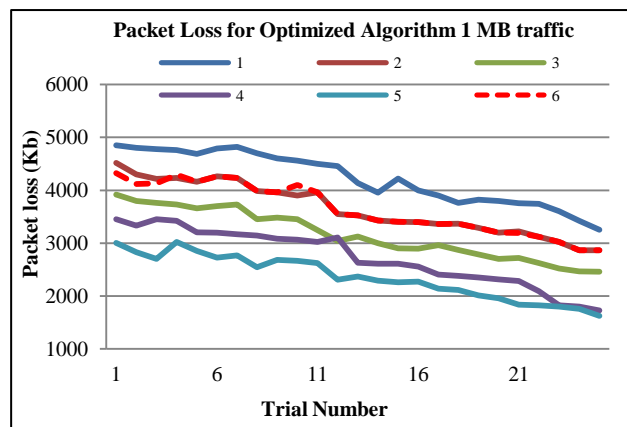

**Fig. 11** Packet loss at the destination when 1 MB of traffic is sent

Time to reach destination from the same origin is measured in seconds. Also there is an ever present unwanted (other people’s traffic) network traffic which is

implemented to mimic a typical network scenario. Both useful traffic and unwanted traffic are generated by the traffic generators and with the purpose of simulating a real networking environment the source of the traffic is randomly selected by the traffic generator. The packet loss at the destination is also measured to assess the reliability of the infrastructure.

The test is carried out in network traffic loads as 1 MB and 8 MB (Mega Bits). The QoS Goal is varied according to the following table and the test results of the original unattended algorithm which was the product of the initial research is also included to help and explain the improvements achieved by the modifications.

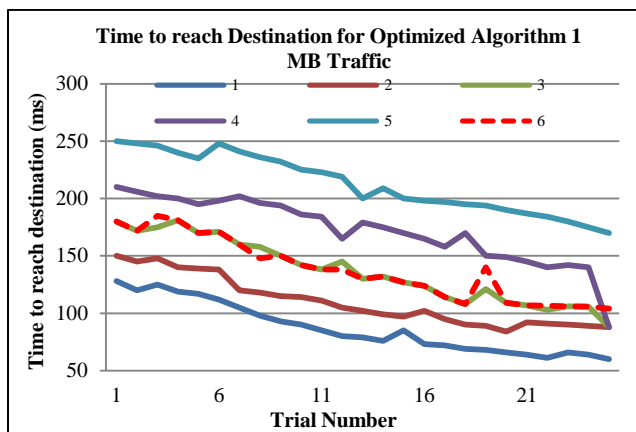

Fig. 12 Time to reach the destination when 1 MB of traffic is sent

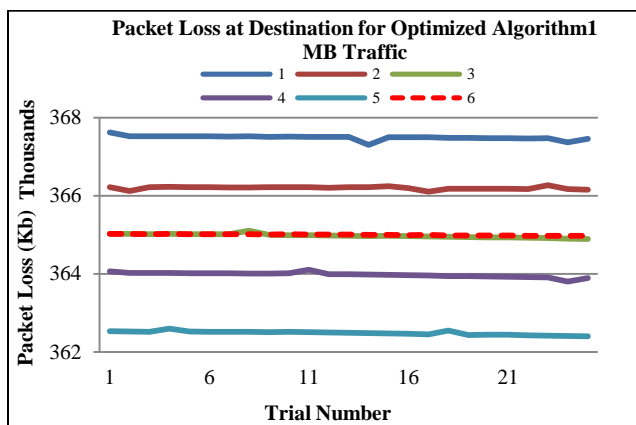

Fig. 13 Packet loss at the destination when 8 MB of traffic is sent

According to these results there are two significant observations in the above graphs. One is that this solidifies the phase one observation of that more the algorithm works the better the results become regardless of the packet loss or efficiency. In neural network based routing algorithm, number of lost packets (as in figure 6 and figure 8) and the time taken to reach a particular destination (as in figure 7 and figure 9) is decreased dramatically with each trial even though in the beginning the algorithm yields poor results (which can be seen in the gradual decline in all the graphs) as the time goes on it is

producing results with significant improvements. Packet loss at the destination also behaves identical to this. Cause for this is the learning and dynamic adaptability of the algorithm which keeps on gathering information about the network and making its routing decisions based on them.

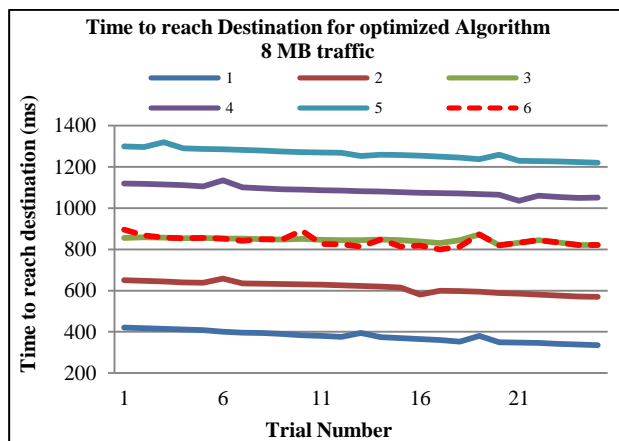

Fig. 14 Time to reach the when 8 MB of traffic is sent.

The other observation is that when the QoS goals are in its extreme ends though the desired result is achieved the other factors deteriorate considerably i.e. when QoS goal weights are set 100% to the minimum delay and 0% to the minimum packet loss though it result in lowest delay among all the test cases it also result in the worst packet loss. More fair allocation of the QoS weights result in better balance between minimum packet loss and minimum delay. It is visible in the above graphs mainly in scenario 3. If there is a requirement of prioritizing one QoS goal over the other it is best to assign them in 25:75 ratio as the test results suggest because then the deterioration of the other factors will be kept at an acceptable level. I.e. scenario 2 and 4 are the ideal situations for prioritizing one QoS goal over the other. If the application/user requests such QoS goals the respective resulting values of the desired QoS parameter as well as any other QoS parameter can be kept at an acceptable level.

**Conclusion**

As the Internet is becoming extremely large and diverse, current network architecture which is based on packet switching can't sustain the demands made by the Internet (Matthew Gray *et al*, 1996). Because of this a user centric, self-adopting and intelligent network is required. During the initial research phase of this research team attempted to address this issue using a routing algorithm based on neural networks and reinforced learning for the cognitive packet network infrastructure and successfully proved that the invented algorithm is suitable and showed that the future lies with this self-sustained and learning network (Petr Grygarek *et al*, 2005). However there were some areas which needed optimization to the algorithm. Thus this research attempt is focused on improving the above mentioned algorithm to suit the rigors needs. Based on the above mentioned test results which were acquired

from the implemented CPN simulation environment, the new neural network based routing algorithm devise a certain pattern of best practices where it suggest against the use of extreme QoS goals (while even when extreme QoS goals presented it performs accordingly but other factors degrade considerably) and suggests that algorithm is best performed when it is given fair QoS goals. The improvements from the initial algorithm was primarily focused on utilization of weighted values presented to the neural network and the decision making and the test results is a testimony for the success of the optimization carried out and these results prove that the new algorithm is suitable for the CPN architecture and it can handle multiple QoS goals without much problem. The research team is currently engaged in testing the network with fine-tuned parameters for more QoS goals, identifying and solving fuzzy areas in routing domain and working towards producing a more efficient, robust & adaptive routing algorithm for cognitive packet network infrastructure.

## References

- Matthew Gray (1996), Internet Growth Summary, <http://www.mit.edu/~mkgray/net/internet-growth-summary.html>. (Online). Available (Accessed: September 05, 2012).
- Marc Abrams (2000), Connection Less vs. Connection Oriented Services, [http://courses.iddl.vt.edu/CS1604/15-Lesson\\_14/04-Connection-Oriented\\_vs\\_Connectionless.php](http://courses.iddl.vt.edu/CS1604/15-Lesson_14/04-Connection-Oriented_vs_Connectionless.php) 1 (Online). Available (Accessed: September 05, 2012).
- E. Gelenbe, R. Lent, Z. Xu (2001), Measurement and performance of Cognitive Packet Networks, *Journal of Computer Networks.*, Vol. 37, pp. 691–701
- Petr Grygarek (Sept 2005), Quality of Service (QoS) in IPnetworks, [http://www.cs.vsb.cz/grygarek/SPS/lect/PREZEN\\_TACE/QoS.pdf](http://www.cs.vsb.cz/grygarek/SPS/lect/PREZEN_TACE/QoS.pdf) (Online). Available (Accessed: September 05, 2012).
- E. Gelenbe, R. Lent, Z. Xu ( Aug 2002 ), Networking with Cognitive Packets, *Proc. ICANN.*, Madrid.
- D.K.D Madubashitha, W.M.S.S Wijesinghe, K.A.S.R Kamaladiwela, M.G.P Ranaweera, Janaka Wijekoon, P.K.W Abeygunawardhana, (2011) An adaptive routing algorithm for Cognitive Packet Network infrastructure based on neural networks, in *Proc. ICIS'11*, Paper 10.1109/ICIINFS.2011.6038041
- Genevieve Orr (1999), Reinforcement Learning, <http://www.willamette.edu/~gorr/classes/cs449/Reinforcement/reinforcement0.html> (online), available (Accessed: February 28, 2011)
- Leslie Smith (2003), An Introduction to Neural Networks, <http://www.cs.stir.ac.uk/>, (online), available (Accessed: February 28, 2011).
- U. Halici (2000), Reinforcement learning with internal expectation for the random neural network *Eur. J. of Opns. Res.*, Vol. 126, no. 2, pp. 288-307.
- K. Pawlikowski, H.-D. J. Jeong and J.-S. R. Lee (2002), On credibility of simulation studies of telecommunication networks, *IEEE communications Magazine*, vol. 40, January 2002.
- S. M. Sanchez (2007), Work smarter, not harder: Guidelines for designing simulation experiments in *Proceedings of the 2007 Winter Simulation Conference*, Washington, D.C., U.S.A., December 2007, pp. 84–94
- E. Gelenbe (2006), "Users and services in intelligent networks", *Proc. IEE (ITS)*, 153 (3): 213-220.

**Dr. Pradeep K.W. Abeygunawardhana** (M'2006) was born on 10<sup>th</sup> August 1976 in Hambantota, Sri Lanka and obtained his bachelor degree from Electrical Engineering at University Moratuwa Sri Lanka in 2002. He obtained his M.Sc. and Ph.D. from Robotics Engineering at Keio university Japan in Sep. 2006 and March 2010 respectively.

He worked as a senior lecturer in Sri Lanka Institute of Information Technology, Sri Lanka for two years. Currently, he is a postdoctoral researcher in Kagawa university, Japan under Regional Innovation Strategy Support Program.